

NORTH AMERICAN SEAL

& Packing Company

530 Van Ness Ave. Fresno, CA 93721
 (559) 264-7325 - Fax: (559) 268-5207

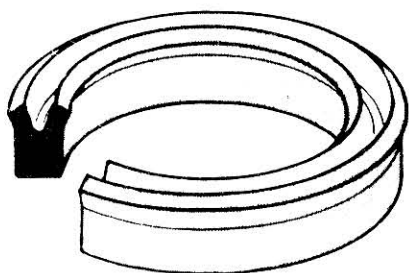

U-CUPS

TYPE UC U
 STYLE 15 (INCH SIZES)

CHARACTERISTICS

North American Seal's symmetrical Urethane U-Cup, is a double chamfered U-Ring seal manufactured from Unithane 395 A liquid cast polyurethane. This material is well known for its superior abrasion resistance, low compression set and resistance to extrusion.

The symmetrical configuration, with equal lip interference and equal heel clearance on both the inside and outside diameters, provides a seal which is capable of use in both rod and piston sealing applications. The sealing lips are knife trimmed to

eliminate all moulding flash and to provide superior low pressure sealing performance.

These seals are available in a full range of standard sizes to fit most piston grooves and packing glands. Tooling is also available for a large range of special sizes.

Type UC U can be easily snapped into a groove or stretched over a one piece piston. Once installed they will immediately return to their original dimensions.

MATERIAL

- TYPE: Unithane 395 A, Liquid Cast Polyurethane
- HARDNESS: Durometer 95 A
- FLUID COMPATIBILITY: See Material Specifications Technical Bulletin

ORDERING INFORMATION

Please review current price list for tooling availability before ordering. A nominal tooling charge may be required for some non-tooled sizes.

Add Prefix UC U to signify a Urethane U-Cup.

e.g. A Urethane U-Cup 2 1/2 I.D. X 3 O.D. X 3/8 H is Part No: UC U 02500300-037

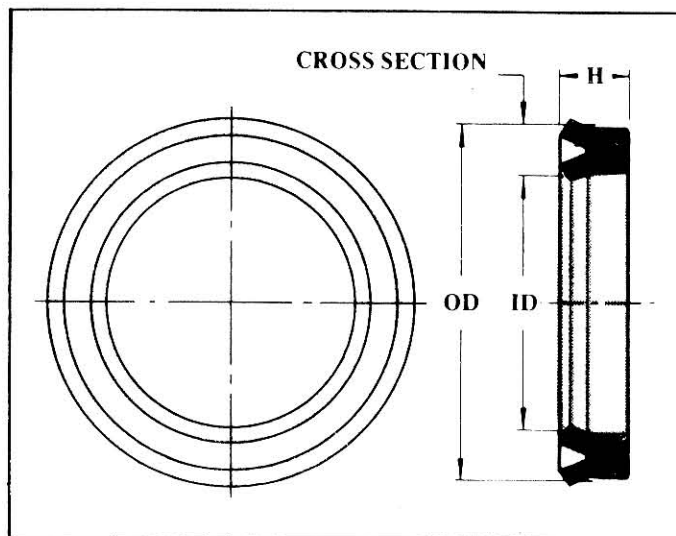

U-CUPS

TYPE UC U STYLE 15 (INCH SIZES)

ROD APPLICATIONS

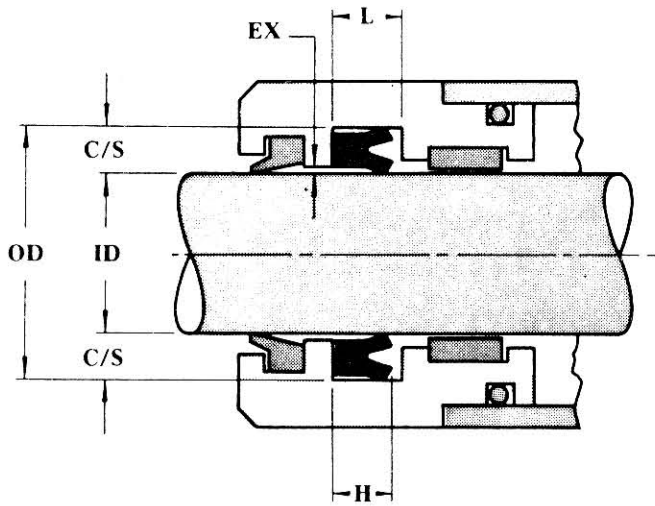

PISTON APPLICATIONS

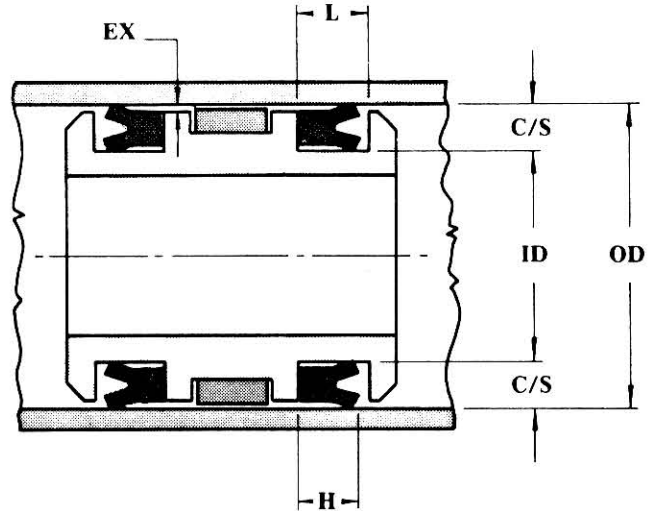

GROOVE WIDTH

H	1/8	3/16	1/4	5/16	3/8	1/2	9/16	5/8	3/4
L	.138	.207	.275	.344	.413	.550	.619	.688	.825
TOLERANCE	+ .015 - .000	+ .015 - .000	+ .015 - .000	+ .015 - .000	+ .015 - .000	+ .015 - .000	+ .015 - .000	+ .015 - .000	+ .015 - .000

GROOVE DEPTH

C/S		DIA. TOLERANCES			
		ROD APPLICATIONS		PISTON APPLICATIONS	
FRAC.	DEC.	ROD. DIA.	GROOVE DIA.	CYL. DIA.	GROOVE DIA.
1/8	.125	+ .000 - .001	+ .002 - .000	+ .002 - .000	+ .000 - .002
3/16	.187	+ .000 - .002	+ .002 - .000	+ .002 - .000	+ .000 - .002
1/4	.250	+ .000 - .002	+ .003 - .000	+ .003 - .000	+ .000 - .003
5/16	.312	+ .000 - .002	+ .004 - .000	+ .003 - .000	+ .000 - .004
3/8	.375	+ .000 - .002	+ .005 - .000	+ .004 - .000	+ .000 - .005
1/2	.500	+ .000 - .003	+ .007 - .000	+ .005 - .000	+ .000 - .007
5/8	.625	+ .000 - .003	+ .009 - .000	+ .006 - .000	+ .000 - .009

SUGGESTED MAXIMUM EXTRUSION GAPS (EX)

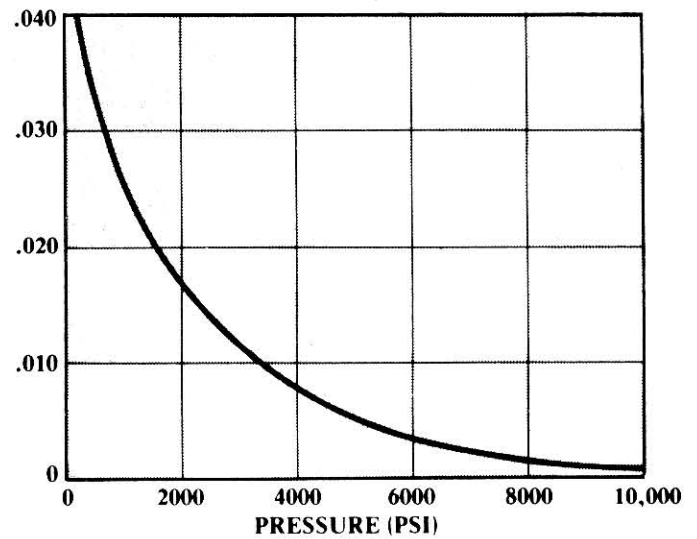

The EXTRUSION GAP CHART provides recommendations for the maximum acceptable extrusion gap at various pressure ranges. Eccentricity, ovality, bearing clearance, and normal wear of the mating parts must be considered when calculating the extrusion gap. This chart is intended as a guide and each application should be thoroughly tested.